

本体外観図・機械寸法：

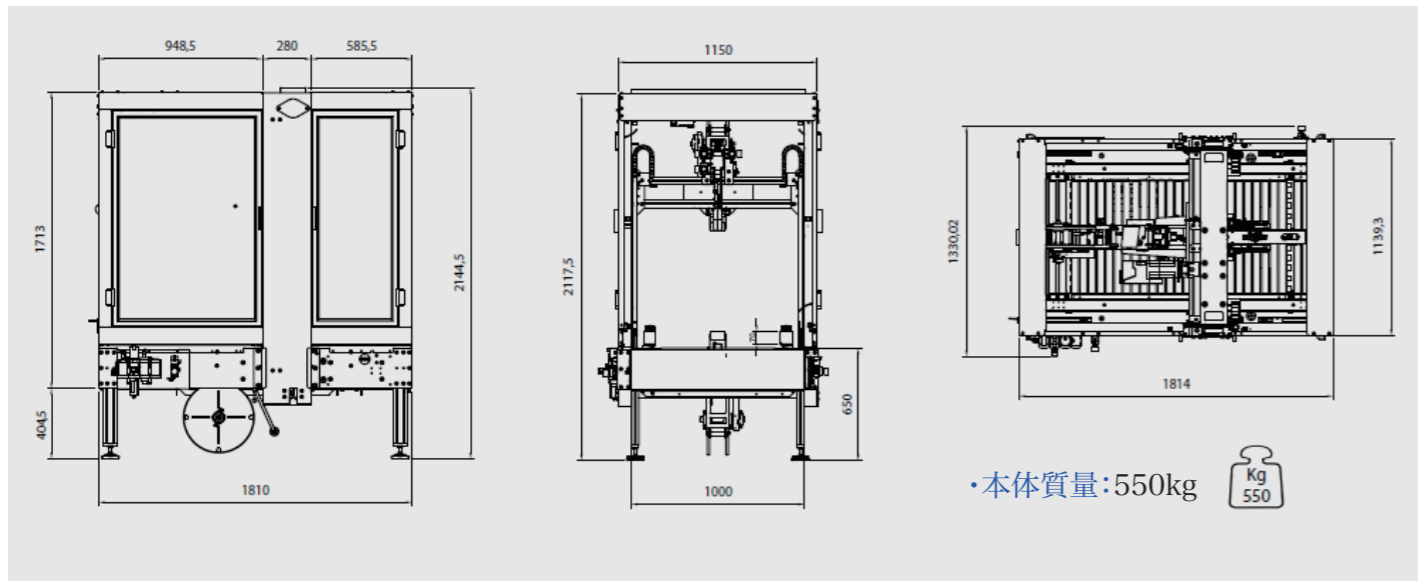

・製函ケースサイズ：

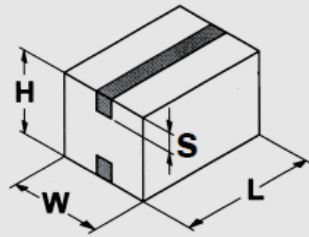

	MIN	MAX
L	300 mm	∞
W	150 mm	650 mm
H	150 mm	650 mm
S	40 mm	80 mm

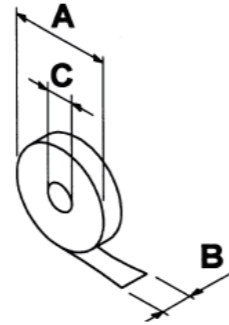

A	MAX 400mm
B	50 ÷ 80 mm
C	70 mm

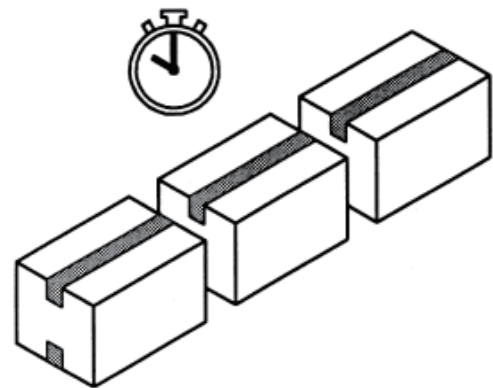

・製函処理能力:420(600)ケース/時

・ケース搬送速度：～18/27mt / min

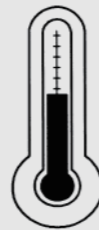

・使用環境温度：

MAX +40°C

MIN +5°C



・消費電力:1.5kW

・動作時空気圧: 6 bar

・毎サイクル消費空気量: 5nl. /6bar

COMARME
SEALING

GEM X670-GP



2024年8月31日版

製品は予告なしに変更になる場合があります。

代理店

チチハル自動機械(株)

〒354-0045 埼玉県入間郡三芳町大字上富2017-9
TEL 049-293-3588 FAX 049-293-3571



TITIHARU

チチハル自動機械株式会社
<https://titiharu.co.jp> info@titiharu.co.jp



Fig. 1 – GP taping head



Fig. 2 – Brushless motor



Fig. 3 - Tester



Fig. 4 - Gummed paper types



Fig. 5 - DCM 670



Fig. 6 - DAC 670

